

Installation, Operation and Maintenance Manual



**“VAPORIZER”
Models: EV- 45 / 55 ADX**

Explosion-proof Construction/NEPSI

All information provided in this manual has been developed over decades of direct involvement in the LPG industry and is believed to be accurate. However, no claim is made that this booklet covers all rules and regulations of all authorities having jurisdiction over all installation sites worldwide.

- This manual is a guide book for “Vaporizer” installation and operation.
- Please read this manual before use.
- For installation construction, please read this manual carefully and understand the details before construction.
- After reading this manual, please keep it carefully by maintenance administrator.

KAGLA VAPORTECH CORPORATION

⚠ WARNING

Please read this before using “ADX” and use it correctly.
Wrong usage may cause serious accidents.



Safety Information

If the “ADX” is improperly operated, this may cause an interruption of gas supply and gas accidents.

 **WARNING** describes things or operation, which could result in injury or loss of life, in the event that product is improperly handled/operated.

 **CAUTION** describes things or operation, which may damage the product, in the event that product is improperly treated or operated.

ATTENTION describes things or operation regarding product performance and/or maintenance.

Warranty

KAGLA warrants that the product is free from defects in materials and workmanship under normal use and service. KAGLA agrees to repair or replace any parts which has proven defective to the satisfaction of KAGLA within eighteen (18) months from the date of shipment or twelve (12) months from the original installation date, whichever comes earlier.

Exceptions under warranty:

If any of the following conditions happens, KAGLA will not accept warranty:

- (1) Malfunction and damage due to using or installing product not in accordance with the manual caused under intentional and/or negligence act.
- (2) Malfunction and damage of product beyond the control of the manufacturer, including but not limited to fire, natural disasters and so forth.
- (3) Modification of product in any way by a third party without the written authorization of the manufacturer.
- (4) Repairs or replacements made by a person other than the manufacturer or its authorized distributor.
- (5) When LPG composition is any of followings:
 - * Composition of Butadiene is over 0.5%
 - * Mixed composition of Ethan and Acetylene is over 0.5%
 - * Weight percentage of Sulfur is over 0.02%
 - * Gas pressure at 40°C is over 1.56MPa
 - * Other than Propane and N-butane composition
 - * Hydrocarbon (C₅) or over C₅ level
 - ※ In order to prevent heavy ends problem, obtain Analysis Table of LPG.
- (6) Any other malfunctions and damages beyond the responsibility of the manufacturer.

Table of Contents

1. Introduction	1
1-1 Specification	1
1-2 Dimensions	3
1-3 How the Vaporizer Works	3
1-4 Name and Function of Components	4
2. Installation	5
2-1 Selecting Installation Site	5
1) Installation Site of “ADX”	5
2-2 Installation of Vaporizer	5
2-3 Piping Construction	6
1) To Maintain Stable Supply of LPG	6
2) Cautions for Piping Construction	6
3) Installation Work on Liquid Inlet Piping	6
4) Installation Work on Gas Outlet Piping	6
2-4 Electrical Construction	7
1) Cautions	7
2) Electrical Wiring and Control Box Diagram	7
3) Electric Connection	8
4) Electrical Grounding Work	9
3. Commissioning	10
3-1 Preparation for Commissioning	10
1) Supply of Power Source	10
2) Supply of LPG	10
3-2 Adjustment of Each Equipment	10
1) Adjustment of Gas Supply Pressure	10
2) Adjustment of Changeover Pressure	10
4. Operation of “Vaporizer”	11
4-1 Instructions and Directions for Use	11
4-2 Supply of LPG	11
4-3 Stoppage of LPG Supply	12
5. Maintenance	13
5-1 Daily Inspection	13
5-2 Troubleshooting	14
5-3 Periodical Replacement of Parts	15

6.Maintenance Management16

6-1 Periodical Inspection16

1) Semiannual Inspection16

2) Annual Inspection16

3) Overhaul Inspection16

7.In Case of Emergency17

8.After-sales Service17

Check manual for opening and closing of solenoid valve

Commissioning Operation check sheet "ADX model"

1. Introduction

1-1 Specification

Model		EV-45ADX	EV-55ADX
Vaporization Capacity		45kg/h / 55kg/h (Refer Vaporization Performance Curve below)	
Gas		LPG (liquefied petroleum gas)	
Heat Source	Type	Electricity	
	Explosion-Proof Heater	4.9 kW	6.0 kW
	Power source	Heater Circuit : Single-Phase AC220V (-0% ~ +10%)	
	Amperage rating	22.3 A	27.3 A
Approximate Control Temperature		63 °C	
Thermal fuse setting		130 °C	
Safety Relief Valve Setting Pressure		250psi(1.72MPa)	
Connection Bore	Liquid Inlet	NPT 1/2	
	Gas Outlet	NPT 1/2	
Dimensions		W 240 x D 180 x H 605 (mm) **Refer dimension drawing	
Approximate Weight		23.5 kg	
Explosion-Proof Cert No.		GYB18.1066X (Ex dIIB T2 Gb)	
Product Standard No.		Q31/0115000515C005	
Standard Accessories		Installation, Operation and Maintenance Manual (This manual) Mounting bolt (M12 x 40L with Plain washer, Spring washer) 4pcs	

ATTENTION

1. Please use “ADX” below vaporization capacity shown on the Performance Curve below.
2. Please use the heater circuit voltage within the range of -0% ~+10% of ratings.
3. In case the below stated requirements are not fully satisfied, vaporizer may not perform on a standard specification as stated on this manual.
 - Gas Composition : Propane 50%, Butane 50% through Propane 100%

EV-45ADX Performance Curve
against Outside Temperature

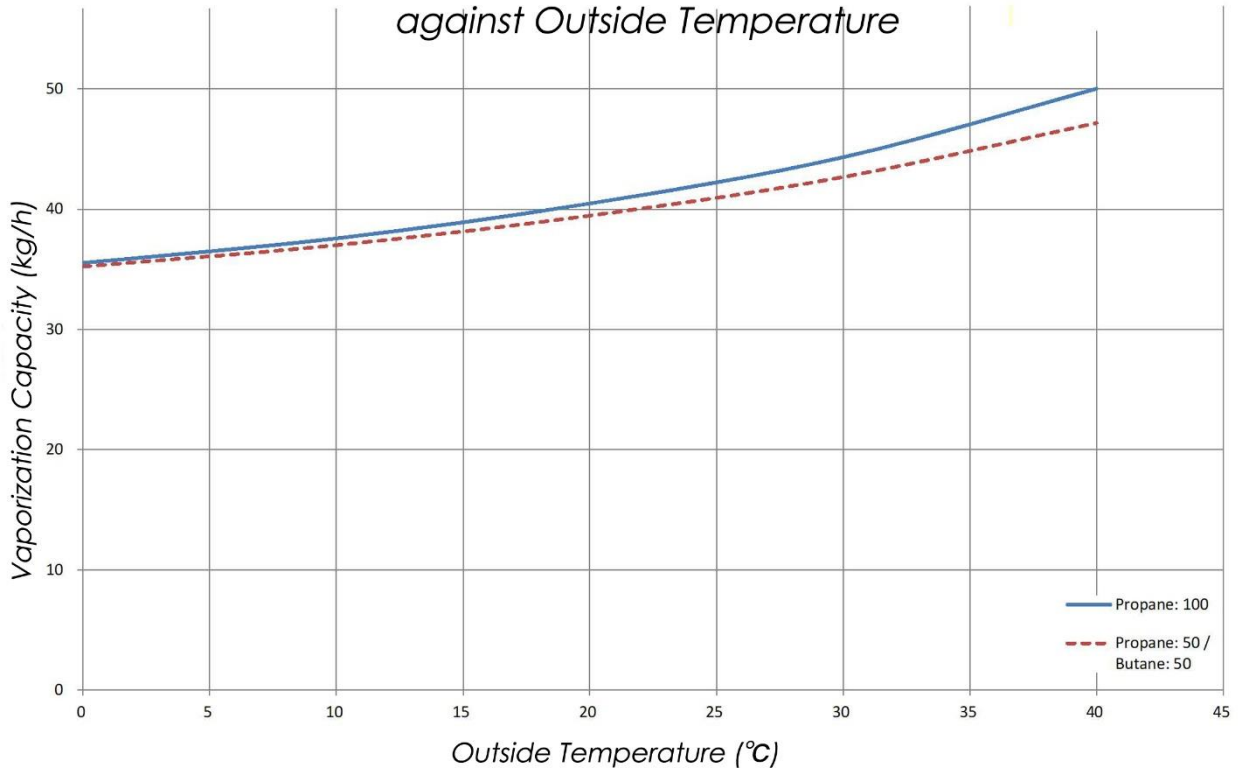

EV-55ADX Performance Curve
against Outside Temperature

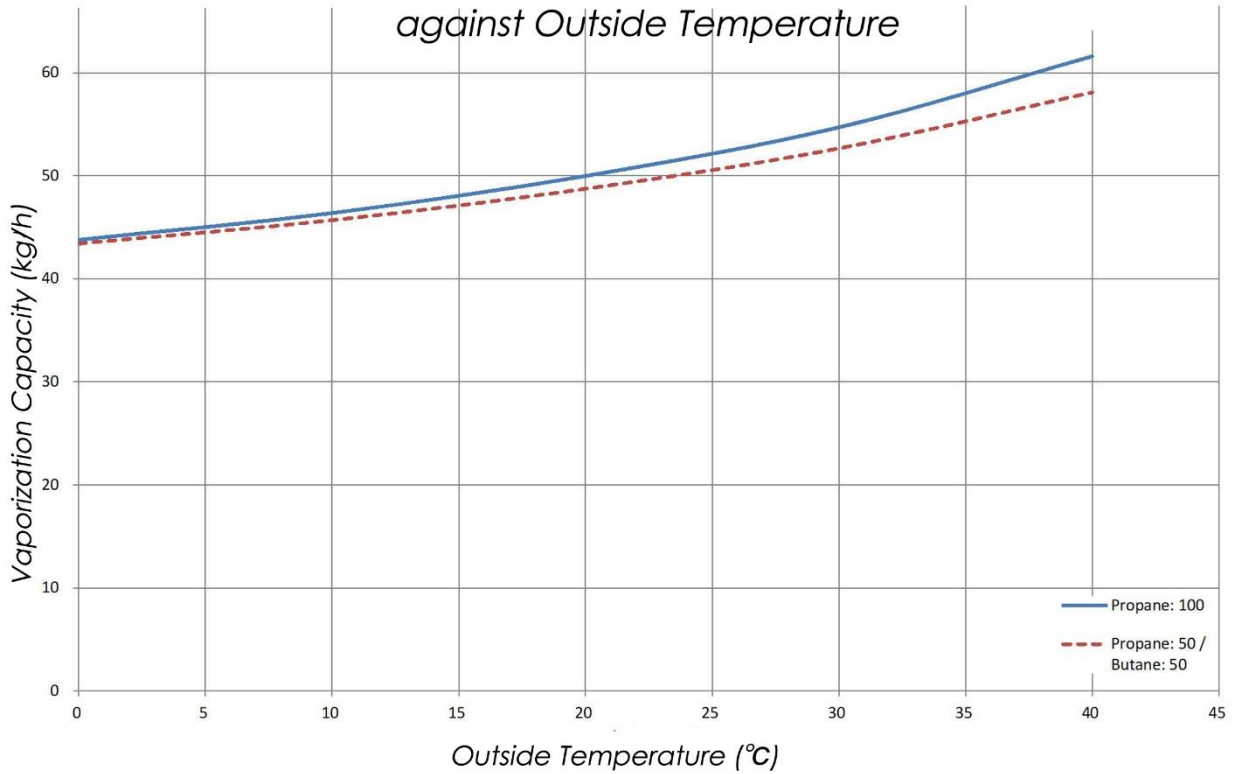

1-2 Dimensions

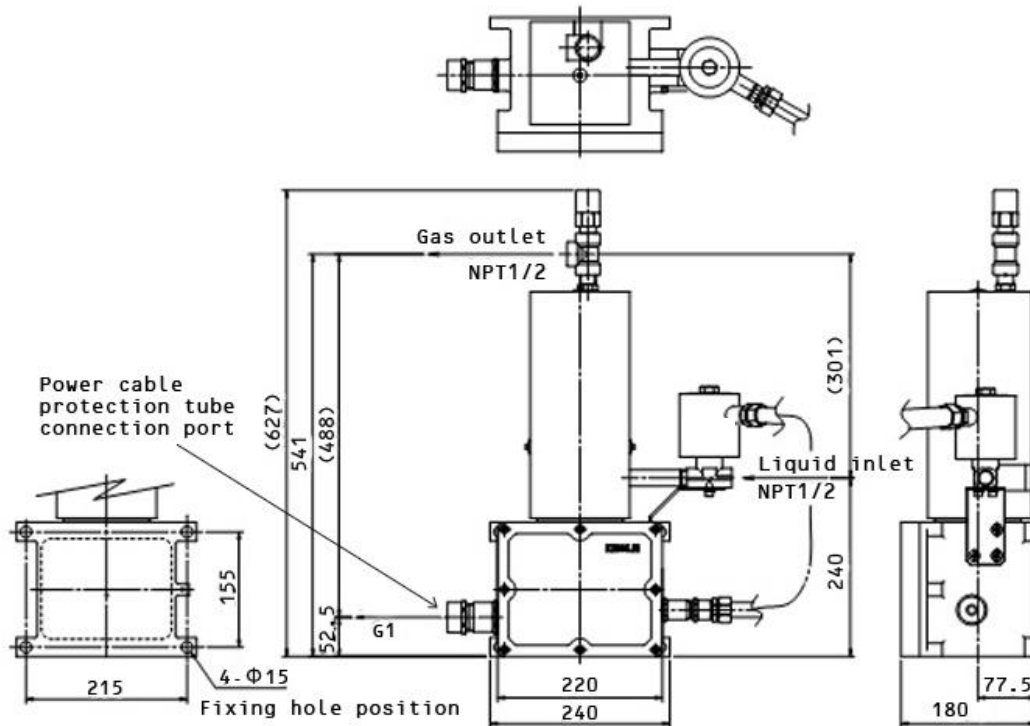

1-3 How the Vaporizer Works

Liquid LPG from cylinder or storage tank goes into the heat exchanger tube of the vaporizer. Inside the vaporizer, temperature of the heat medium is controlled at the range between 58~68°C by temperature controller for stable vaporization. Thermal energy transfers from heat exchanger to liquid LPG and causes LPG vaporization. Install pressure regulator (prepared by user) to control gas outlet pressure and supply LPG vapor to consumption site with appropriate pressure.

Several safety measure is prepared for “ADX”.

Solenoid valve positioned at the liquid inlet of the vaporizer functions as a liquid carry over prevention device. It is activated at abnormal temperature decline of heat medium (Aluminum casting) in order to prevent liquid carryover in the event of overcapacity consumption and blackout. Once the temperature of heat medium recovers to normal (setting) range, the solenoid valve opens automatically and resume gas supply.

Thermal fuse prevents overheating by cutting off electric heater and shutting the solenoid valve in the event of abnormal temperature rise of heat medium (setting temperature 130°C). In case the thermal fuse is activated, eliminate the cause of heating error and then contact the distributor to arrange maintenance work.

Safety relief valve is equipped to protect vaporizer from being damaged at the event of abnormal pressure rise inside the heat exchanger.

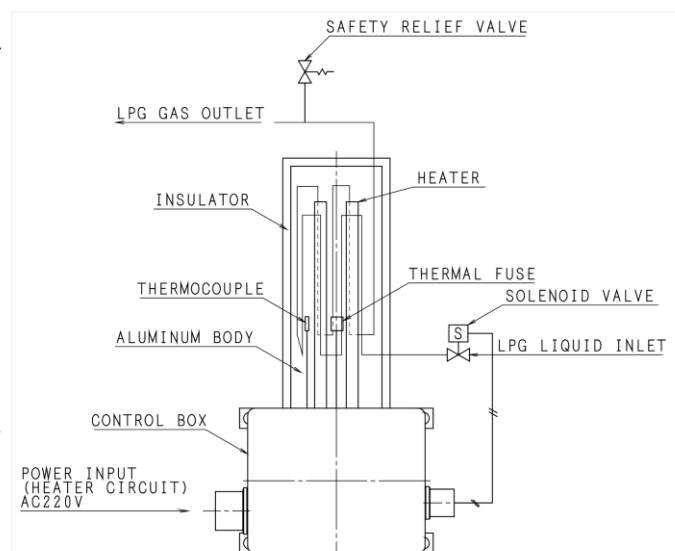

1-4 Name and Function of Components

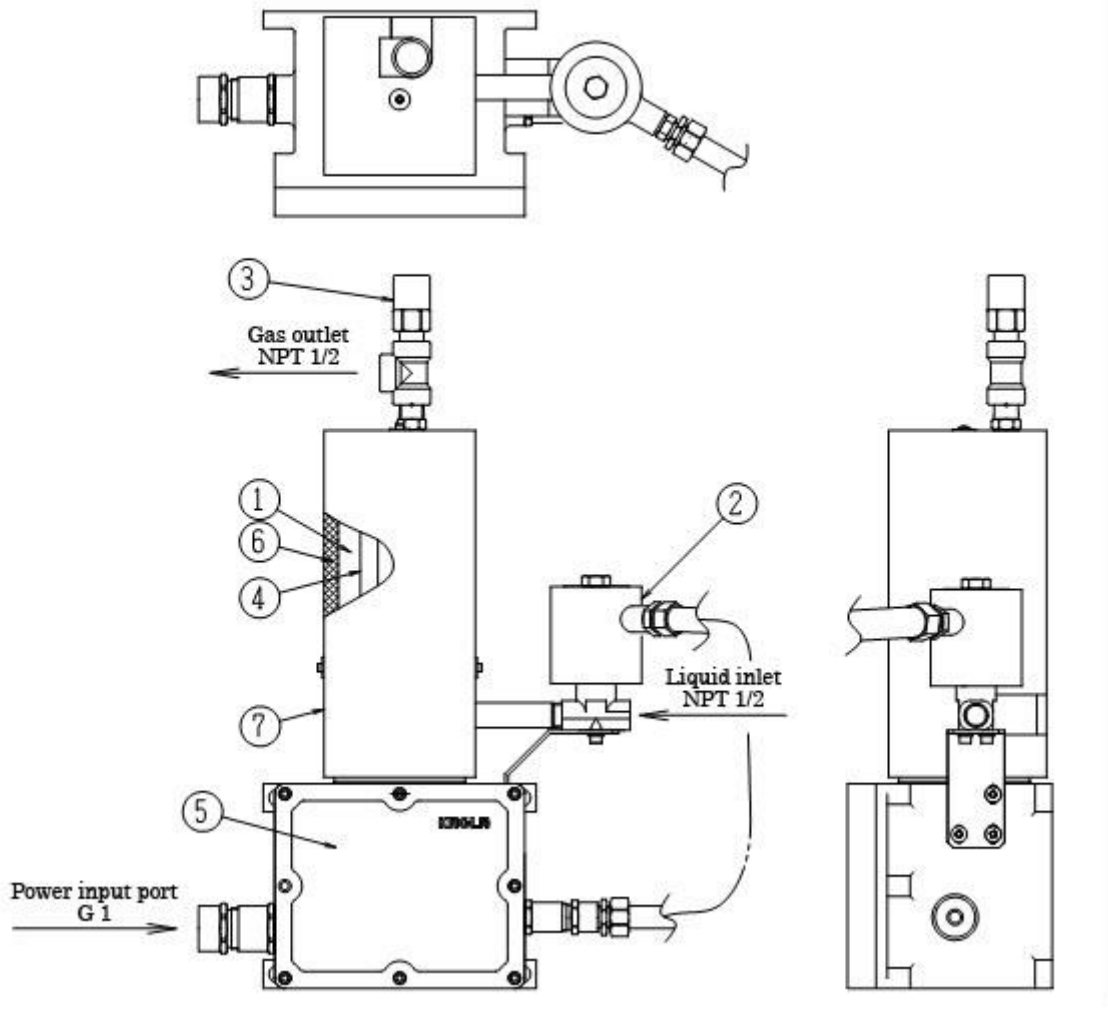

1	Heat Exchanger	Vaporizes liquid LPG.
2	Solenoid Valve	Prevents liquid carryover and be activated by temperature of heat exchanger.
3	Safety Relief Valve	Opens when abnormal pressure inside the heat exchanger occurs to prevent damage of the heat exchanger.
4	Electric Heater	Heats heat exchanger.
5	Electric Control Box	Flame-Explosion-Proof construction Electric parts contained inside the box.
6	Insulator	Prevents heat radiation from heat medium.
7	Cover	Protects the accessories and decorative purpose.

2. Installation

2-1 Selecting Installation Site

1) Installation Site of “ADX”

▲ CAUTION
Select the installation site according to below instruction in order to secure the safety in case of gas leakage and other accidents.

- ① Install “ADX” at least 8 meters away from facilities that use flames.
- ② Install “ADX” at a place where there is no entrance to water drainage (to avoid LPG accumulation in case of leakage).
- ③ Install “ADX” at a place with good ventilation such as outdoors. In case of installing inside facility, ventilation must be provided. (It requires ventilation opening of 300cm² or more per 1m².)
- ④ Install the explosion-proof gas leakage detector covering “ADX” including piping and tank, etc.
- ⑤ Provide some working space surrounding the area of “ADX” for maintenance and inspection.
- ⑥ Select the site where it is free from corrosive gas such as Chlorine, Dust, Hydrogen Sulfide, Ammonia and etc.
- ⑦ Display “Flames Prohibited” where “ADX” is installed, and place at least 6kg of Fire Extinguisher.

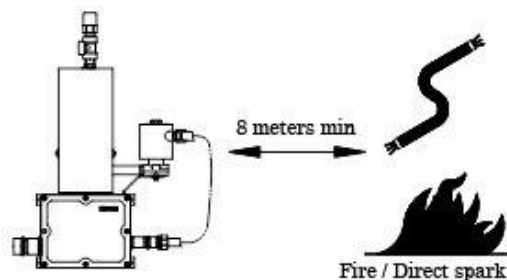

2-2 Installation of Vaporizer

Place “ADX” to the surface of a wall by passing a flat washer and spring washer through mounting bolt (M12x40L: attached accessory) or other appropriate bolts to fit.

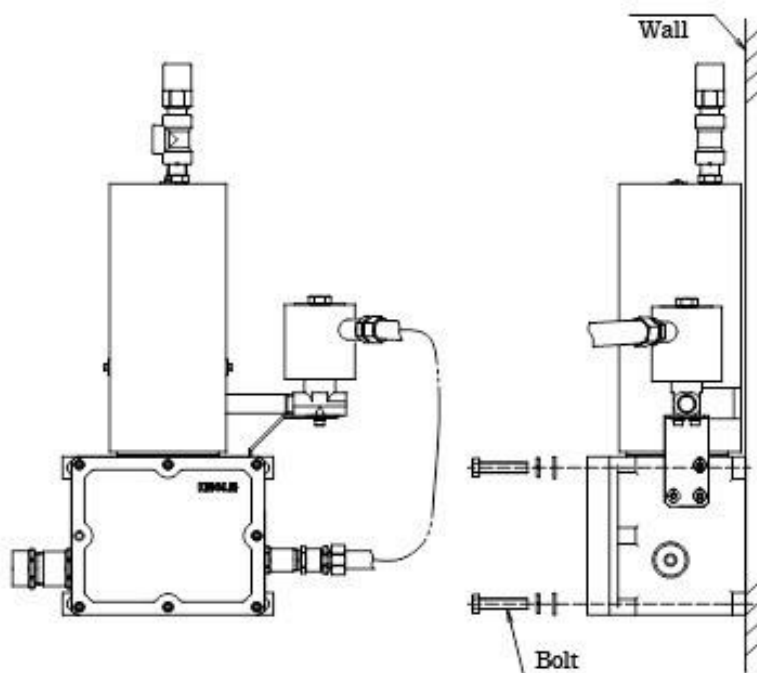

2-3 Piping Construction

1) To Maintain Stable Supply of LPG

If the vaporizer is expected to be operated for 24hours, or if severe loss against production is assumed in case LPG supply stops, please prepare following measurements.

- ① Install natural vaporization (vapor bypass line) line from a storage tank.
- ② Install a backup vaporizer equivalent to the vaporization capacity in use.

2) Cautions for Piping Construction

- ① Use pipes and valves with sufficient strength to match operation pressure range.
- ② Install heavy ends drain valve at the bottom part of upstroke supplying line.
- ③ Set up piping and wiring work in a way that they can be disconnected easily for maintenance.
- ④ Secure at least 15cm distance between gas piping and copper piping which contain wires. Avoid crossed piping and wiring.
- ⑤ Take necessary actions to eliminate static electricity.
 - a. Earth connecting wire requires cross-sectional area of more than 5.5mm^2 , and it must be connected individually.
 - b. Earth resistance rate is under 100Ω . However, if a condenser lightning arrester is provided, the rate is under 10Ω .
- ⑥ Prior to the piping connection to “ADX”, make sure inside of piping is clean.

▲ CAUTION

In case debris such as rust enters into “ADX”, it may cause problems in operation of vaporizer. Clean all debris remaining inside the piping by flashing with a nitrogen, etc. prior to connecting.

When making the inlet and outlet connections to “ADX”, remain the hex part of metal fitting and avoid unnecessarily force on to “ADX” and screw into piping. If you don't retain and screw in, vaporizer's piping will be damaged.

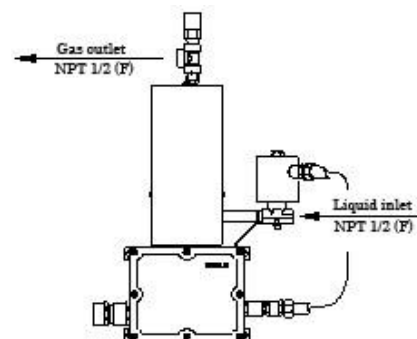

3) Installation Work on Liquid Inlet Piping

- ① The liquid strainer is not provided in the unit. Be sure to install a strainer at the liquid inlet of “ADX”.
- ② Install the stop valve before strainer.
- ③ Install pressure gauge to liquid inlet piping (2.0MPa:Recommended).
- ④ Do not use non-return valve for hoses and valves at liquid piping.

4) Installation Work on Gas Outlet Piping

- ① Pressure regulator is not included in the package. Prepare and install it on the user's side.
 - ② To avoid LPG re-condensation, be sure to install a pressure regulator as close as possible to the gas outlet of “ADX” at the position higher than gas outlet.
 - ③ Install a stop valve at the pressure regulator outlet.
 - ④ Install a pressure gauge to the piping after pressure regulator (0.3MPa:Recommended).
 - ⑤ To avoid LPG re-condensation, use heat insulation equipment as needed.
- Despite heat insulation measurement is completed, LPG re-condensation may still occur by change of gas composition, temperature and supply pressure. In this case, take proper

measurement such as “increasing Propane composition of LPG” or “decrease supply pressure”.

- ⑥ If installing an oil trap, install at the outlet of the pressure regulator to avoid re-condensation.

▲ CAUTION

Vapor LPG being vaporized by the vaporizer is likely to recondensate when the gas temperature goes down. If the pressure regulator is positioned lower than the gas outlet of the vaporizer, recondensate LPG liquid will not return back to the vaporizer. And thus there is serious risk that it can flow to the consumption side in liquid state.

2-4 Electrical Construction

Make sure to perform explosion-proof wiring work, as “ADX” is an explosion-proof equipment.

1) Cautions

- ① No Turn On / Turn Off switches are equipped with on the “ADX” body. Make sure to arrange the independent earth leakage breaker at the “ADX” Power-input side.
- ② Use the power supply cable insulated by rubber or vinyl or polyethylene suitable to your location. Please refer to table below for the cable size.

Model	EV-45ADX	EV-55ADX
Heater Capacity	4.9kW	6.0kW
Cable Size	Above 5.5 mm ²	
Power Input Port	NPT 1	
Solderless Terminal Size	For M4	

- ③ Electrical Control Box of “ADX” is Explosion-proof. (flame-proof enclosure structure) Please refer to the following “Flame-proof Cable Gasket Wiring”.
When closing the control box lid after electrical wiring, make sure that no foreign matter is attached to the O-ring and that it is correctly fitted into the mounting groove.

▲ CAUTION

Closing the lid with foreign matter attached to the O-ring or not fitted in the groove may cause a malfunction.

2) Electrical Wiring and Control Box Diagram

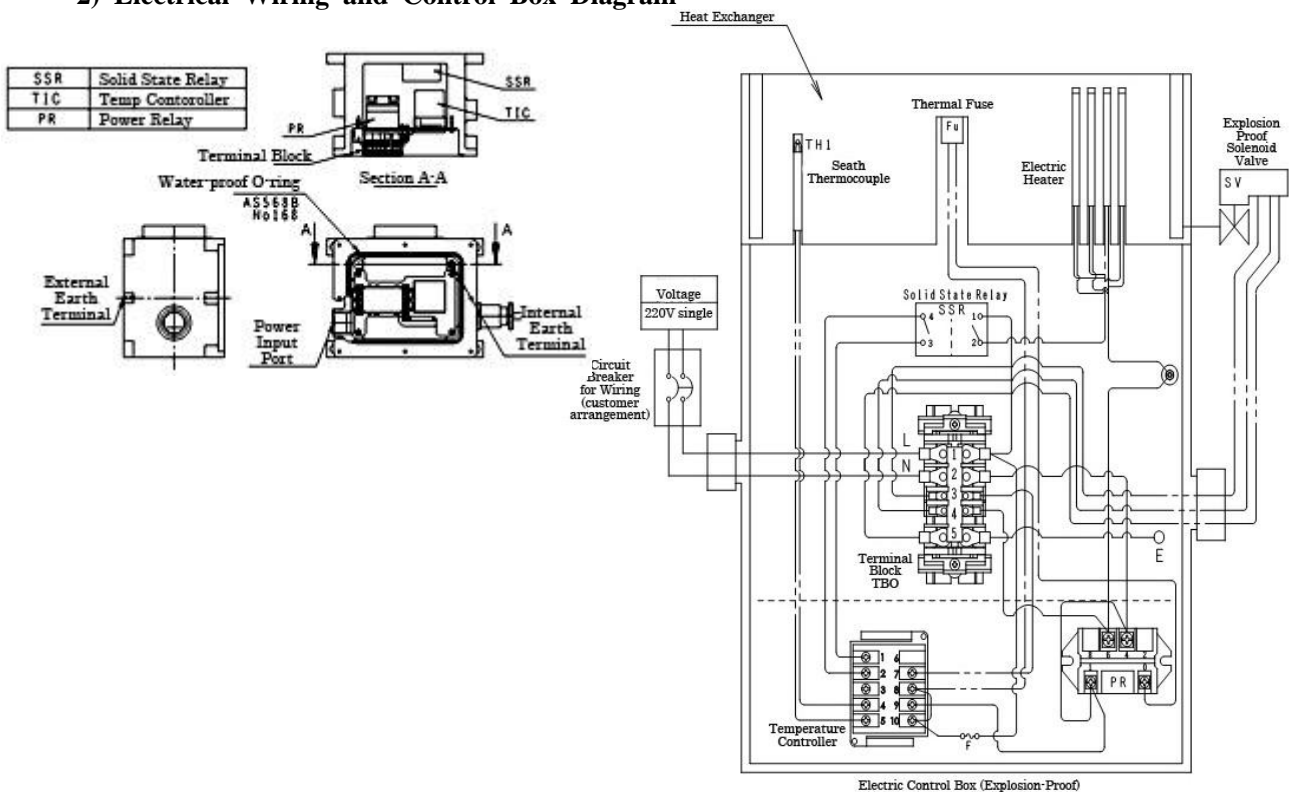

3) Electric Connection

Flameproof gasket cable wiring

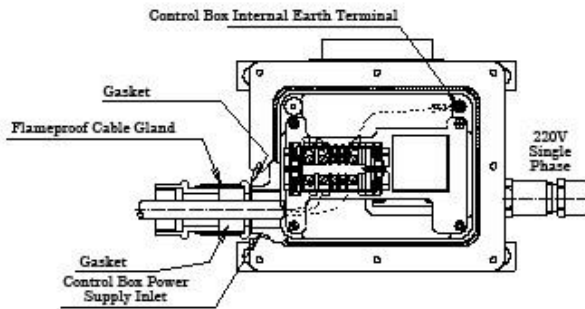

- ① Arrange the independent earth leakage breaker at the “ADX” Power-input side.
- ② The Supply Cable Wiring needs to be Explosion-proof (flame proof enclosure) in accordance with the above diagram.
- ③ Remove the cover of electric control box and attach Solderless Terminal on terminal block in the box or above-mentioned sized Solderless Terminal at the end of the cable.
- ④ Pull the cable into the Control Box and directly connect to “1” and “2” of terminal block.

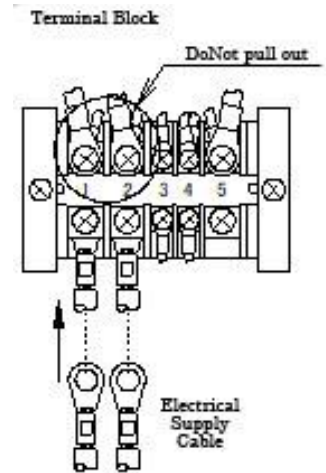

▲ CAUTION

- Electric wire initially attached to “1” and “2” is for getting the electric supply of the control circuit. Do not pull them out and screw tight with Electrical Supply Cable.
- Loose connection at terminal may cause malfunction of “ADX” and burnout of terminals. Use an appropriate tool and tighten securely.

- ⑤ After connecting the electric supply, tighten the lid of electric control box without making any gap.

▲ CAUTION

When you close the lid on the control box, set water-proof O-ring properly into the slot, so that it could not be loosened out.

- ⑥ Take the applicable measures in order to prevent rain drops or moisture from flowing into cable inlet.

1. Use 2 cores (3 cores if using internal ground terminal) insulated sheath cable.

2. Use a gasket that matches the size of cable diameter.

3. Push in cabled Flameproof gasket fitting into service entrance of electric control box. Make sure that Flameproof gasket fitting and service entrance must be geared up 5 threads at least.

4. Tighten power cable gasket after connecting in order to satisfy explosion-proof function.

4) Electrical Grounding Work

In order to prevent a direct-spark or other ignition source caused by high temperature, make sure to apply grounding work.

- ① Use vinyl insulated grounding cables with insulation performance of over 600V.
- ② To ground Electric Control Box, use electric wire thicker than the size of power supply connection wire. For grounding the Electric Heater, use the wire thicker than 5.5 mm².
- ③ Ground resistance value should be under 100 Ω.

Connect the grounding line to external grounding terminal of Electric Control Box and the individual grounding terminals of Electric Heater.

When connecting the ground wire, connect it with the ground terminal of the solenoid valve which is already connected.

Connection of electric control box

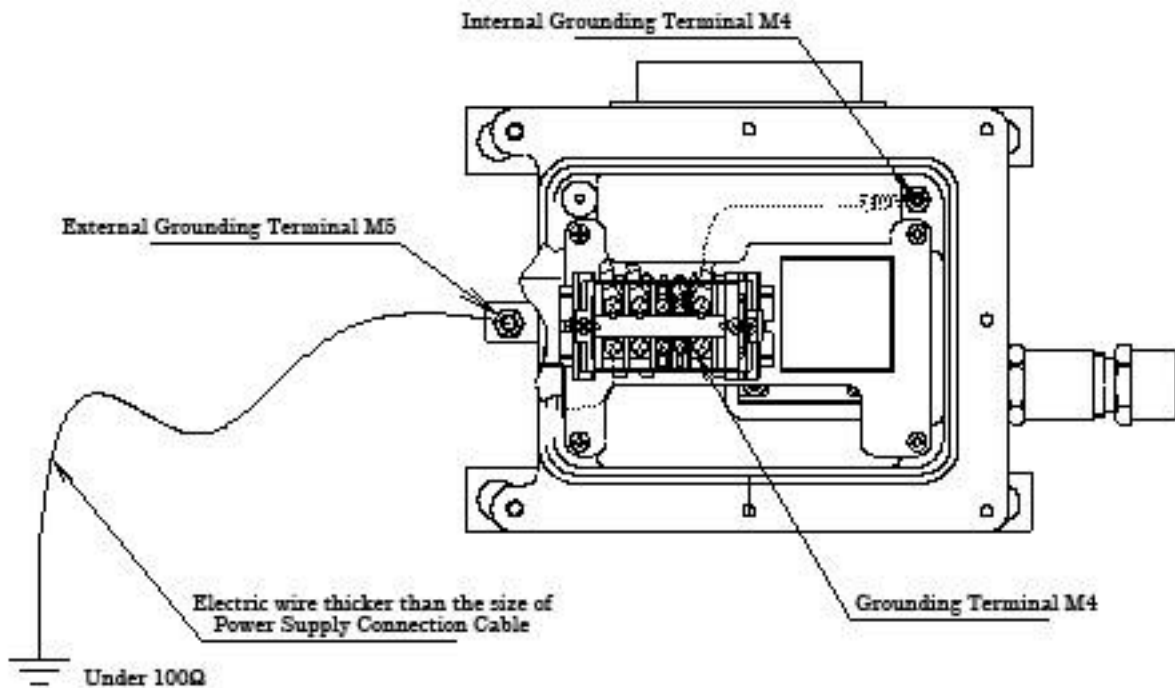

3. Commissioning

This section explains about commissioning procedure. Perform all tests stated in test run check sheet at the end of this manual and make sure there is no error.

3-1 Preparation for Commissioning

1) Supply of Power Source

Make sure the lid of electric control box is completely closed. Turn on the electrical breaker to activate the “ADX” vaporizer. Once power supply starts to “ADX”, leave it for approximately 5 min. When the temperature of heating medium reaches approximately 63°C, LPG vapor supply will be possible.

▲ CAUTION
It is highly dangerous to supply power while electric control box lid is opened. Electric spark may become an ignition point.

2) Supply of LPG

Refer to “4-2 Supply of LPG” and start the supply of LPG.

3-2 Adjustment of Each Equipment

1) Adjustment of Gas Supply Pressure

Adjust pressure regulator so that the pressure gauge installed to gas piping after pressure regulator will indicate the set pressure.

ATTENTION
Adjustment of gas supply pressure should be done while consuming LPG.

2) Adjustment of Changeover Pressure

If the Liquid Auto Changer is installed, changeover pressure needs to be set as well. By opening and closing the valves of storage tank or cylinder to control liquid supply, let the changeover function. While operating changeover, adjust changeover pressure. It must be set above the adjusted pressure of regulator during operation. For details, refer to the operation manual of Liquid Auto Changer you are using.

4. Operation of “Vaporizer”

4-1 Instructions and Directions for Use

(1) No Flames Allowed

Flames include “Fire” and “Direct-Spark”, etc.

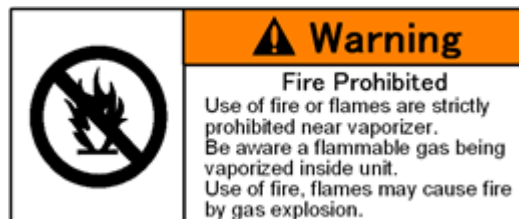
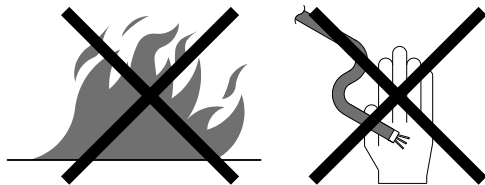

(2) Prevention of Electrification

- As Electric Control Box uses a high voltage, be careful when wiring not to get an electric shock.
- Please ask a professional engineer when checking inside Electric Control Box for maintenance.



4-2 Supply of LPG

- ① Check the open/close state of valves.

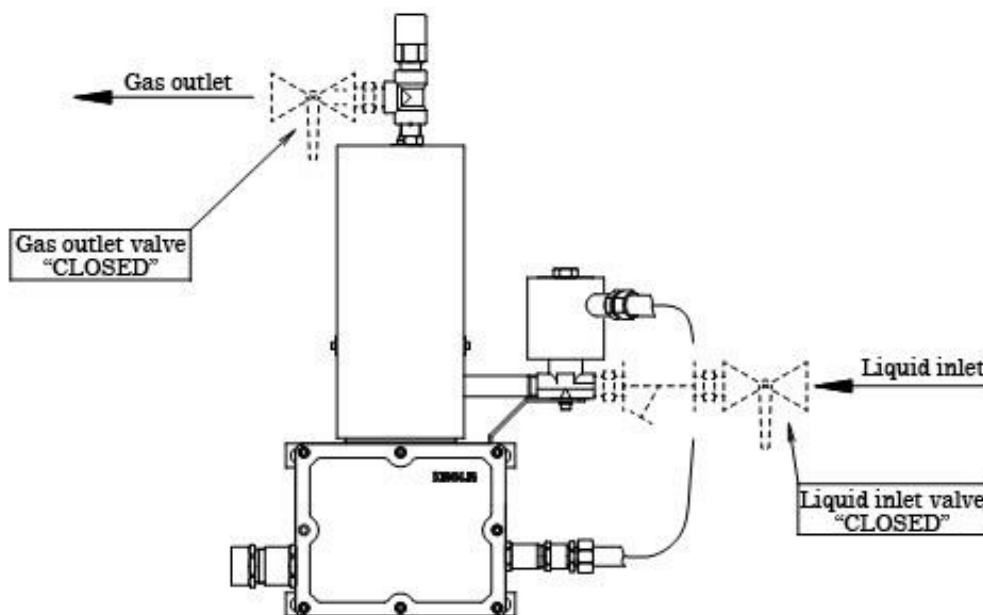

- ② Open the valves of cylinders and storage tanks, and supply LPG up to the liquid inlet valve of “ADX”. (prepared by the user)
- ③ When power is supplied and heating medium is above set temperature, solenoid valve will open.
- ④ Gradually open liquid inlet valve and finally open fully.
- ⑤ Gradually open gas outlet valve. (User installation)

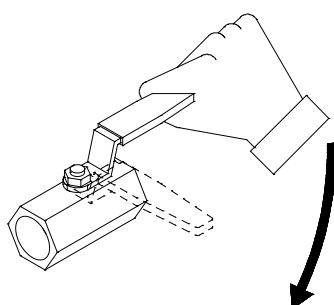

ATTENTION
If the gas outlet valve is opened suddenly, the solenoid valve may close due to temporary overload.

4-3 Stoppage of LPG Supply

- ① When stopping gas supply temporarily while heater is ON, close gas outlet valve (installed by the user) of vaporizer only. Leave other valves kept at operational positions.

▲ CAUTION

In order to prevent abnormal increase of pressure caused by liquid seal inside the vaporizer, do not close the liquid inlet valve except for the time when draining out LPG liquid inside “ADX” for long term stoppage.

- ② When stopping operation for a long term, close liquid inlet valve and consume LPG vapor completely. After consuming all LPG inside “ADX”, turn “OFF” the power line breaker and close gas outlet valve.

5. Maintenance

5-1 Daily Inspection

Daily inspection items, methods, criteria and troubleshooting are summarized as follows. If problems cannot be solved by this troubleshooting, do not attempt to solve by yourself and make sure to contact LPG supplier or our distributor for the overhaul inspection.

ATTENTION
* Daily inspection is to be carried out three times a day - before, during and after the operation. * Even if “ADX” runs 24 hours a day, inspect three times a day. * Keep “Daily Inspection Record”.

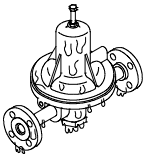
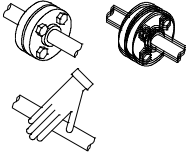
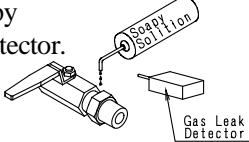
	Inspection Item and its Method	Normal Condition	Solution if Condition is Abnormal
① Operational Test	Check if frost is on the gas outlet piping. 	No frost on the gas outlet piping.	Call for inspection and repair.
① Operational Test	Check if there is any vibration on gas outlet piping by touching. 	No vibration.	Call for inspection and repair.
② Leakage Test	Check all gas connection for leaks using a soapy solution or gas detector. 	No leaks at all.	Call for inspection and repair.

5-2 Troubleshooting

If the “ADX” becomes abnormal conditions during operation, refer to the following chart for investigation and appropriate measures. If troubleshooting can’t solve your problem, contact your local LPG supplier or our distributor for their inspection.

Problem	Check Item	Solution
Heat exchanger temperature doesn't increase.	Is the power properly supplied?	Start the supply of power to “ADX” after confirming the control box is completely closed.
Heat exchanger temperature abnormally increase.	Is the temperature controller properly working? (operation temperature 58~68°C)	Contact LPG supplier / distributor.
No gas supply.	<ol style="list-style-type: none"> 1. Are the valves of consumption side opened? 2. Isn't the heat medium temperature lower than 50°C? 3. Isn't the solenoid valve shut off? 4. Isn't the LPG Liquid Inlet Strainer (installed by the user) clogged? 5. Does LPG run out? 6. Failure of valves on pipe. 	<ol style="list-style-type: none"> 1. Open the valves if any closed. 2. Solenoid valve opens at 50°C+. 3. Need replacement of electric heater if it is disconnected. 4. Clean up strainer. 5. Contact LPG supplier / distributor. 6. Adjust regulator etc.
Solenoid valve shut off during operation.	<ol style="list-style-type: none"> 1. Was there a blackout? 2. Is the power voltage normal? 3. Is the LPG consumption within vaporization capacity of “ADX”? 4. More than 2 vaporizers operated in parallel? 	<ol style="list-style-type: none"> 1. Turn the power on. ※ If the gas is consumed during blackout temperature of heat medium will decrease and cause solenoid valve to shutoff. 2. Control Power Voltage must be within 0%~+10% of rated voltage. 3. Reduce amount of gas consumption or use bigger capacity vaporizer. 4. If more than 2 vaporizers are operated in parallel at the same time, consumption may be biased to a specific vaporizer's line and cause overload by consuming more than vaporization capacity.
Vapor pressure is abnormally lower than the storage tank and liquid inlet piping pressure.	Isn't the LPG Liquid Inlet Strainer (installed by the user) clogged?	Clean up the Strainer.
Supply pressure is lower than set pressure.	<ol style="list-style-type: none"> 1. Is vapor pressure sufficient? 2. Readjusted the supply pressure (by resetting regulator)? 	<ol style="list-style-type: none"> 1. Refer to above “Vapor pressure is much lower than the storage tank and liquid inlet piping pressure”. 2. Refer to the operation manual of Regulator and adjust the supply pressure.

Problem	Check Item	Solution
Supply pressure is higher than set pressure.	—	Refer to the operation manual of Regulator and adjust the supply pressure.
Gas leaks from Safety relief valve	Safety relief valve needs to be replaced.	Close liquid inlet valve of ADX and contact the supplier.
Frosting on pressure regulator and/or gas piping.	Is amount of LPG consumption within its capacity?	Reduce amount of gas consumption or use bigger capacity vaporizer.

5-3 Periodical Replacement of Parts

Please contact our distributor regarding periodical replacement of parts. Replace the periodical replacement parts by referring to “**6-1 3) Overhaul Inspection**”. Overhaul Inspection requires specialized knowledge and skills. Please ask your LPG supplier or our distributor for the service of overhaul inspection.

Followings are the parts to be replaced when overhaul inspection is carried out.

Periodical Replacement Parts List

Demarcation	No.	Parts Name	Replacement Cycle
Protective Equipment	1	Solenoid valve	Within 3 Years
	2	Safety Relief Valve	Within 5 Years
Others	3	O-ring	Within 3 Years

- * The timing of inspection and parts replacement differs depending on quality of LPG, installed environment and operational conditions.
- * Replacement cycle does not match the parts life.

ATTENTION
We are able to supply repair parts (the parts required for maintaining product function) for 10 years after production is discontinued. Please note that price and delivery time of these replacement parts after servicing period may be different from those in early years.

6. Maintenance Management

6-1 Periodical Inspection

In order to assure safe operation of “ADX”, we recommend following periodical inspection. Also, comply with your local regulations for inspection requirement, if you have any.

1) Semiannual Inspection (6 months)

We recommend following inspection every after 6 months to maintain safety operation of vaporizer.

- ① Check gas leaks on all piping, valves, flange connections, bolting and welding parts.
- ② Check if there is abnormal sound on electric control box.
- ③ Check if the set pressure (supply pressure) of pressure regulator is appropriate.
- ④ (If the liquid auto changer is installed,) check if the changeover pressure is appropriate.
- ⑤ Perform a solenoid valve open / close check test. (Refer to the attached maintenance manual.)

2) Annual Inspection

We recommend following inspection to be done every year to maintain good performance and safety operation of vaporizer. Upon above 5 inspection, perform followings as well.

- ① Perform operation test (measure the pressure when discharging and resetting) of the safety valve.
- ② Perform pneumatic test at 1.5MPa on the heat exchanger and piping by using Nitrogen gas (N₂).
- ③ Check if the insulating resistance of electric heater exceeds 1MΩ.

3) Overhaul Inspection

We recommend that first overhaul inspection be scheduled in two years after the installation, and perform every three years after first one. In overhaul inspection, perform detailed inspection which cannot be done by semiannual and annual inspection, and replace periodical replacement parts such as o-ring and valve sheet, etc. inside the solenoid valve.

- ① Check if there is any rust on the surface of body and piping.
- ② Replace the parts listed on “**5-3 Periodical Replacement of Parts**”.

▲ CAUTION
* For inspection period and details, please plan based on the law, regulations and inspection standards of your country or area.
* Conducting periodical inspection requires expertise and skill.
* Ask LPG supplier or our distributor for conducting periodical inspection.

7. In Case of Emergency

◆ In case of accident caused by LPG leakage, fire and earthquake, etc, please practice following procedures:

- ① Contact facility management personnel.
- ② Stop LPG consumption.
- ③ In case LPG is leaking, immediately manipulate valves, etc. of cylinder and emergency shutoff valve, and prevent LPG from flowing out.
- ④ Stop using flames to prevent LPG from catching fire, and open the cylinder storage and ventilate, etc. and diffuse LPG.
- ⑤ In case of fire, try to extinct the fire at primary stage and lead neighbors to evacuate.
- ⑥ Call the fire department, police and related department, if necessary, to prevent expansion of the fire accident.

8. After-sales Service

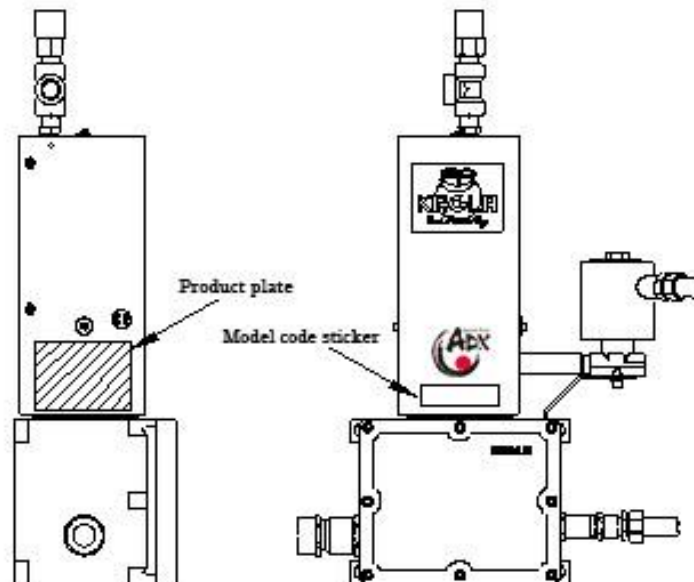

① When seeking technical assistance, please inform us of the following, when you seek for after-sales service.

- | | |
|----------------------------------|--|
| (1) Model and Product NO: | It is stated on the product plate. |
| (2) Installed Date: | Check the commissioning check sheet. |
| (3) Situation: | Inform us as much information as possible. |
| (4) Contact Details of End-user: | Name, Address and Phone number. |

② Product plate is affixed on the left side of “ADX” body.

*** For inspection, repair and failure of equipment, please contact us or our distributor.**

Distributor

HDM0173 R2

Check manual for opening and closing of solenoid valve

Step1: Close the liquid inlet valve and consume all LPG inside "ADX".

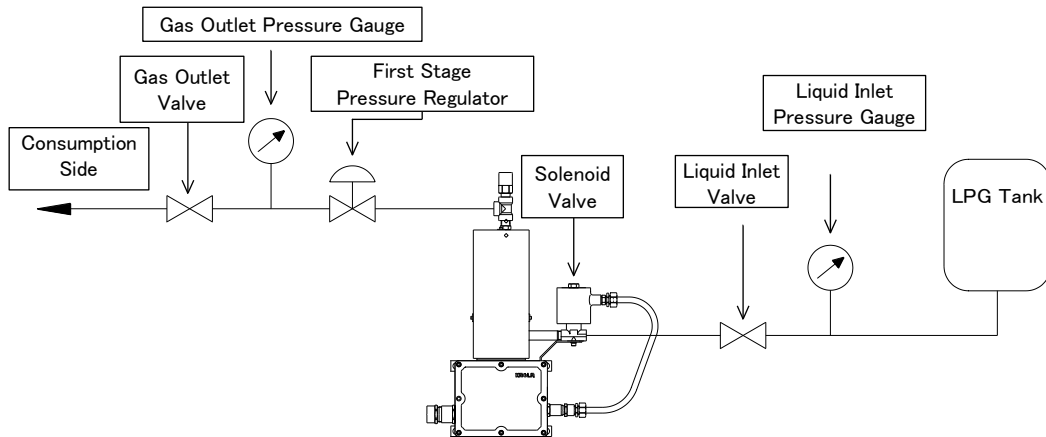

Step 2: Turn OFF the breaker of the power line and close the gas outlet valve.

Step 3: Allow the heat exchanger surface to cool down to surrounding temperature.

Remove the cover of "DX" and check the temperature of the heat exchanger surface (see figure below).

If the temperature is down to your **body temperature**, you are ready to start.

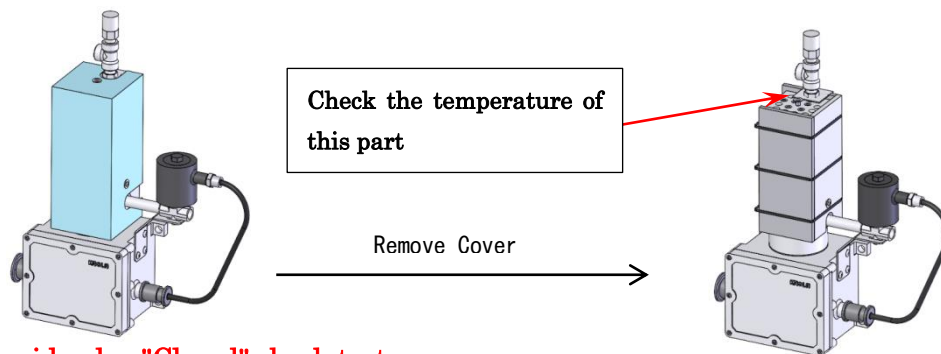

Step 4: Solenoid valve "Closed" check test

Open the liquid inlet valve and check the pressure of the gas outlet pressure gauge

Pressure gauge value	Judgment	Treatment
0 MP a	OK	—
Rise up to supply pressure	NG	Solenoid valve is not "closed" Start maintenance of solenoid valve.

Step5: Solenoid valve "Opened" check test..

Turn on the breaker of the power line.

When the temperature of "ADX" rises, the solenoid valve opens along with the operation sound of the solenoid valve. Check the pressure gauge value.

Pressure gauge values	Judgment	Treatment
0MPa	NG	Solenoid valve is not "opened". Contact Kagla
Rise up to the supply pressure	OK	-

Step 6: If OK, restart operation.

