



FILTAIRE™

Contaminant Separator



The **FILTAIRE™** is a filtering device designed to trap heavy hydrocarbons commonly present in LP gas vapor and other materials that may be in the gas due to storage conditions and internal conditions of the equipment.

Impurities are collected in the system and periodically removed through a system drain valve. Residual heavy end hydrocarbons with boiling points higher than pure LPG are trapped by the internal filter and fall to the bottom for removal.

Features

- ◆ Capacities of 20 gph (40 Kg/hr) through 6000 gph (12,000 Kg/hr) @ 20 psig
- ◆ Drain Valve
- ◆ Design pressure of 250 psig @ 650 Deg. F.
- ◆ Models F0.5 – F6 screwed inlet and outlet connections
- ◆ Models F8 – F30 300# Flanged inlet and outlet connections
- ◆ Optional single or dual liquid level switches available factory installed to warn user the FILTAIRE™ requires draining due to the accumulation of liquid in the reservoir.

Model	*Nominal Flow Rate GPH
F0.5	20
F3	26
F4	102
F6	230
F8	405
F10	635
F12	920
F14	1250
F16	1630
F20	2550
F24	3670
F30	5735

- ◆ The FILTAIRE™ F0.5 is designed specifically for use with the ZIMMER™ Electric Vaporizer
- ◆ *Nominal Flow Rate is rated at 20 psig
- ◆ Flow Rates will vary depending on pressure

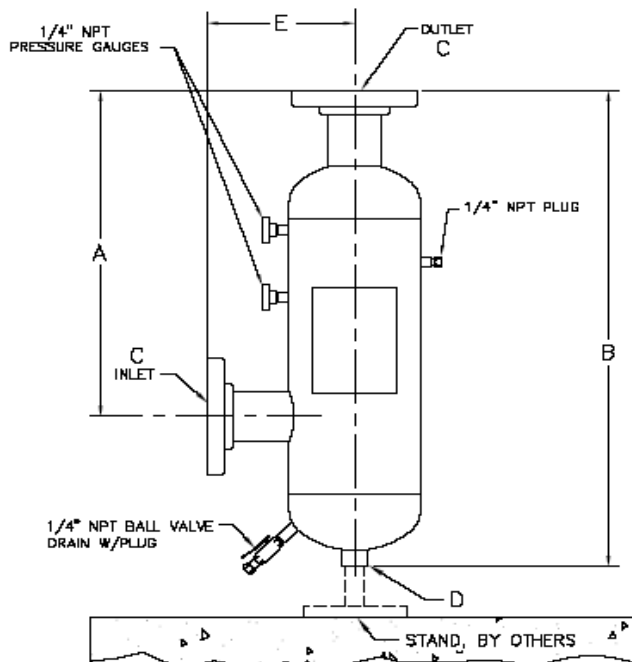

Model	F3	F4	F6	F8	F10	F12	F14	F16	F20	F24	F30
A	17"	19"	20 1/2"	23"	25"	27"	33"	35"	43 1/4"	43 1/2"	43 1/2"
B	24"	27 1/4"	30 1/4"	33 1/2"	37 1/2"	41 1/4"	48 3/4"	51 3/4"	66 1/4"	66 1/2"	66 1/2"
C ⁽¹⁾	1 1/2" NPT	1 1/2" NPT	2"	3" 300# Flange	4" 300# Flange	6" 300# Flange	6" 300# Flange	6" 300# Flange	6" 300# Flange	6" 300# Flange	8" 300# Flange
D ⁽²⁾	1"	1"	1"	1"	2"	2"	3"	3"	N/A	N/A	N/A
E	5 1/2"	5"	6 1/4"	9 1/4"	10 3/8"	11 3/8"	12"	13"	16"	18"	23"

- (1) Screwed connections: Models F3 & F4 – 1 1/2" full coupling 3000# F.S.; Model F6 – 2" full coupling, 3000# F.S.
 (2) Models F20-F30 complete with stand (not shown above).

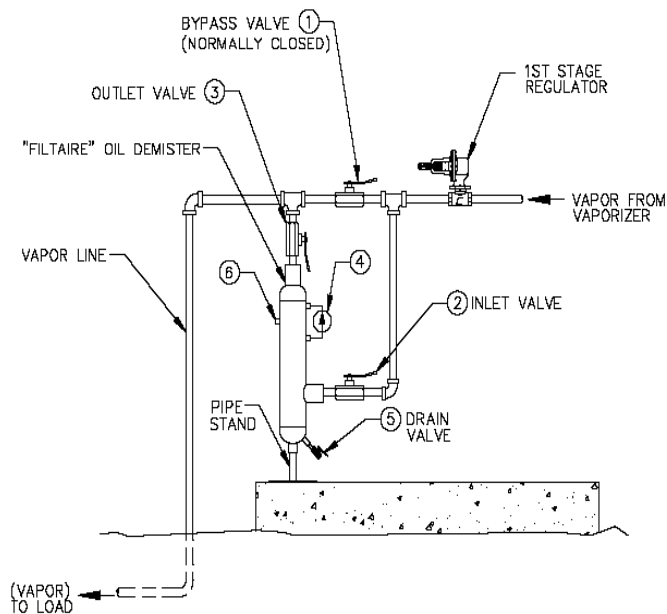

Typical FILTAIRE™ installation shown. Items supplied with standard unit are (4) differential pressure gauges, (5) drain valve, (6) vent, normally plugged. Items (1), (2) and (3) – the bypass valve system for cleaning to be supplied by others at time of installation.